

SITE SUMMARY
 ZONING: CR-D1
 REQUEST: Off premise alcohol sales in conjunction with a general merchandise or food store less than 3500 s.f.
 EXISTING USE: General merchandise or food store less than 3500 s.f.
 REQUIRED PARKING: 17
 PROVIDED PARKING: 21

Z190-221 SITE PLAN

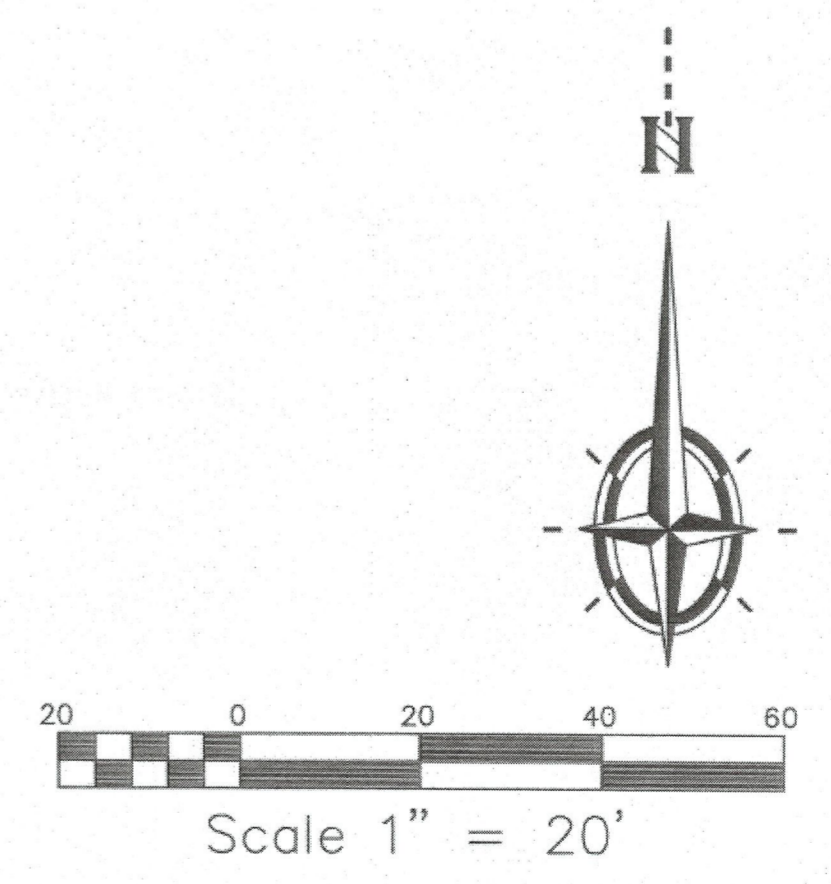
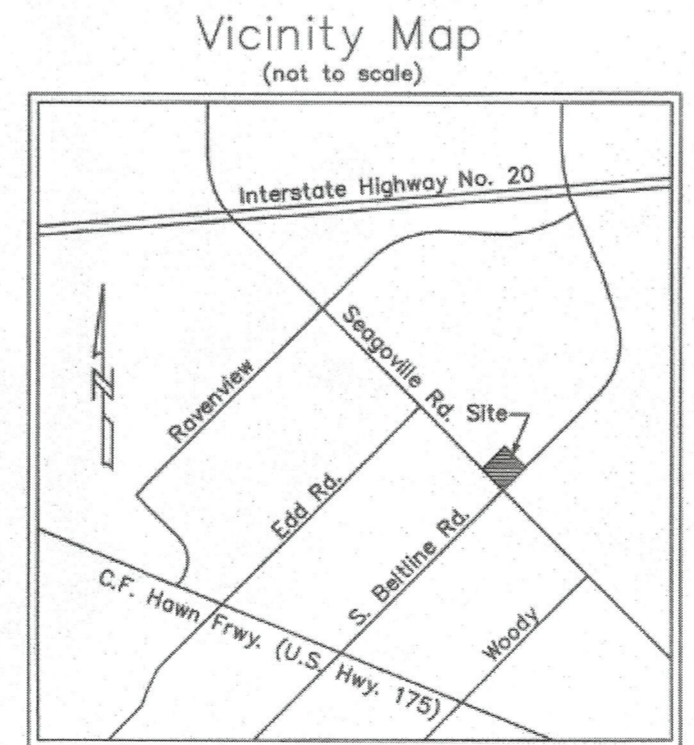

Property Zoned CR/D-1
 Beer/Wine off-premise/Mixed in restaurants with certificate

 SURVEYING ASSOCIATES 1018 SOUTH BECKLEY AVE. DALLAS, TEXAS 75203		DRAWN BY Lynn L.
		JOB NO. 11-205-L

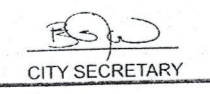
31630 APPROVED BY CITY COUNCIL SEP 09 2020  CITY SECRETARY	201354	Specific Use Permit No. 2393 Approved City Plan Commission July 9, 2020
--	--------	---

Sheet 1 of 1