

N. HASKELL AVENUE
(VARIABLE WIDTH RIGHT-OF-WAY)

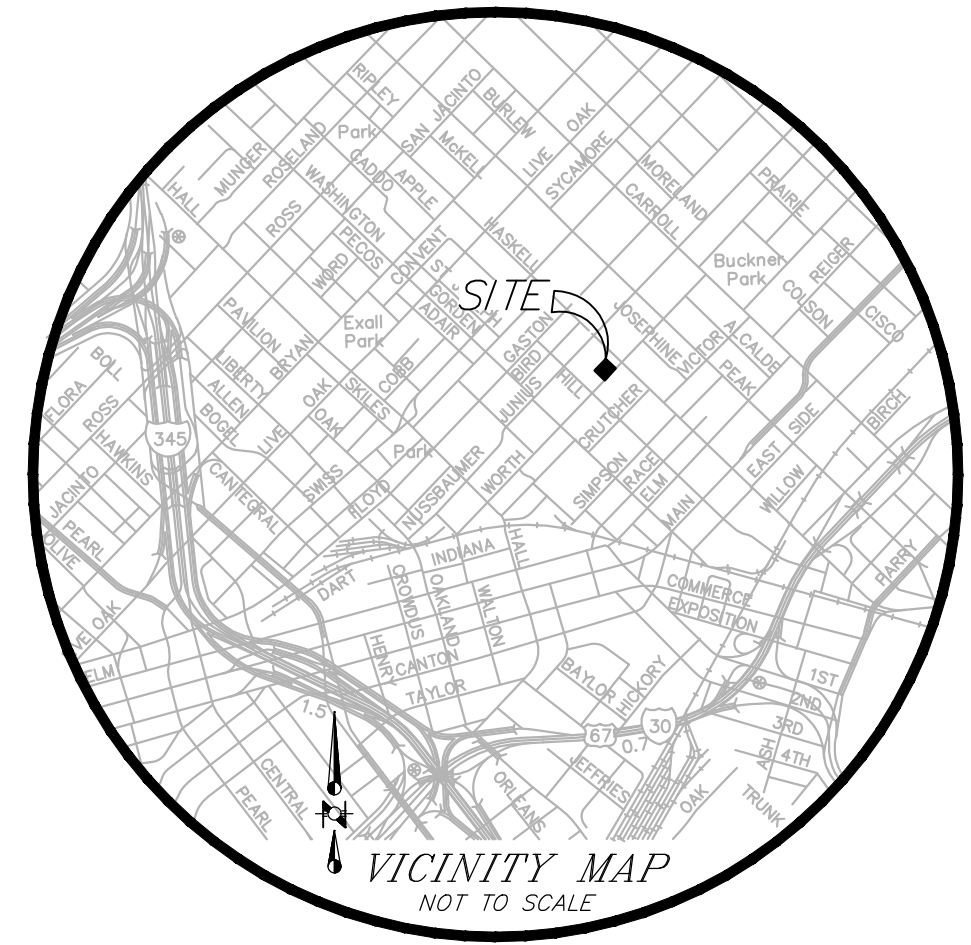
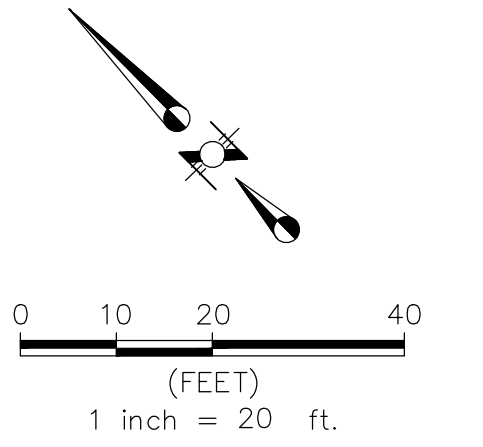

CALLED 0.1170 ACRES
 AGAPE CLINIC
 TRACT III
 INST. NO. 201500277398
 O.P.R.D.C.T.

CALLED 3977 SQ FT
 OWEN MALLOY INVESTMENTS
 LLC
 TRACT 1
 INST. NO. 201600100943
 O.P.R.D.C.T.

CALLED 0.1659 AC
 OWEN MALLOY INVESTMENTS LLC
 TRACT 2
 INST. NO. 201600100943
 O.P.R.D.C.T.

AMBULATORY
SURGICAL
CENTER

PROPOSED DUMPSTER
 W/ ENCLOSURE

LOT 8A, BLOCK D/790
26,254 SQUARE FEET
0.6027 ACRES

S44°18'49"W 136.76'

WORTH STREET
(VARIABLE WIDTH RIGHT-OF-WAY)

N44°28'29"E 136.57'

N45°22'47"W 189.49'

CALLED 0.2975 ACRES
 BAYLOR HEALTH CARE SYSTEM
 INST. NO. 202000083244
 O.P.R.D.C.T.

REVISED PLAT OF
 W.B. MILLERS ADDITION
 BLOCK D/790
 VOL. 84 PG. 597
 M.R.D.C.T.

20' ALLEY

LOT 5A, BLOCK C/789
64,236 SQUARE FEET
1.4746 ACRES

BAYLOR HEALTH CARE SYSTEM
 TRACT 2
 VOL. 83014, PG. 3909
 D.R.D.C.T.
 LOT 4

CALLED 0.5811 ACRES
 BAYLOR HEALTH CARE SYSTEM
 VOL. 2002164 PG. 2745
 O.P.R.D.C.T.

SITE SUMMARY TABLE	
REMOTE PARKING FOR MEDICAL CLINIC OR	
AMBULATORY SURGICAL CENTER USE	
PROPOSED PARKING	56 spaces

RLG CONSULTING ENGINEERS
 12001 N. CENTRAL EXPRESSWAY #300 DALLAS, TX 75243
 5601 BRIDGE STREET #420 FORT WORTH, TX 76112
 WWW.RLGINC.COM TBPE FIRM REG. F-493

ZONING EXHIBIT - PARKING LOT LAYOUT

BS&W DALLAS SURGICARE

LOT 7-9, BLOCK D/790

CITY OF DALLAS, DALLAS COUNTY, TEXAS

REVIEW	DRAWN	DATE	FILE	NUMBER	SHEET
RLG	RLG	11/01/23	2213	015	----