

**APPLICATION FOR A CERTIFICATE OF APPROPRIATENESS FOR  
A SIGN IN A SPECIAL PROVISION SIGN DISTRICT (SPSD)**

**DOWNTOWN SPECIAL PROVISION SIGN DISTRICT**

---

**CASE NUMBER:** SIGN-26-000549

**DATE FILED:** Mar. 26th, 2026

**LOCATION:** 1845 WOODALL RODGERS FWY  
(EAST ELEVATION)

**SIZE OF REQUEST:** 72.3 sq. ft.

**COUNCIL DISTRICT:** 14

**ZONING:** PD-193, HC

---

**APPLICANT:** Gary Houser of 4D Signworx LTD.

**OWNER:** WDC FUB OFFICE OWNER LLC

**TENANT:** Gary Reed & McGraw LLP

**REQUEST:** An application for a Certificate of Appropriateness by Gary Houser of 4D Signworx LTD., for a 72.3-square-foot back lit channel letters sign mounted on a four-inch deep pan on the Eastern facing façade at 1845 WOODALL RODGERS FWY (EAST ELEVATION).

**SUMMARY:** The applicant proposes to install an illuminated flat attached sign, totalling 72.3-square-foot. One set of five-inch back lit channel letters mounted on a four-inch deep pan, reading 'Gray Reed' with Logo

**STAFF RECOMMENDATION:** Approval.

**SSDAC RECOMMENDATION:** Approval.

**BACKGROUND:**

- The subject site is located in the Perimeter Subdistrict of the Downtown Special Provision Sign District and is zoned PD-193, HC, Oak Lawn Special Purpose District. These regulations are established in: [Sec. 51A-7.900](#) (Specific details included below).
- The applicant proposes to install an illuminated flat attached sign, totalling 72.3-square-foot. One set of five-inch back lit channel letters mounted on a four-inch deep pan, reading 'Gray Reed' with Logo
  - The sign is composed of channel letters mounted to a four-inch deep pan. The channel letters, "GRAY REED.", are painted Black with white acrylic faces and black one-inch trim-cap. LOGO to be 1st surface Cardinal Red 3M vinyl applied to the acrylic faces.
  - Sign elements are constructed entirely of metal, plastic, and LED lighting. The overall height of the sign will not exceed three-feet.
- This is the first of two applications under review by this body for this site. This sign is to be facing North St. Paul Street and is submitted as "Sign A".
- Construction of the proposed sign is in accordance with SPSD regulations and meets the requirements of the Dallas City Code per Sec. 51A-7.900.

**51A-7.902**      **PURPOSE.**

The purpose of this division is to regulate both the construction of new signs and the alterations of existing signs with a view towards enhancing, preserving, and developing the unique character of the downtown area while addressing the diversity of businesses and promoting the economy of downtown. The general objectives of this division include those listed in Section 51A-7.101 as well as aesthetic considerations to ensure that signs are appropriate to the architecture of the district, do not obscure significant architectural features of its buildings, and lend themselves to the developing retail and residential uses and the pedestrian character of the area. The district regulations are in large part inspired by the high level of pedestrian activity and the need to maximize effective orientation of signage toward the walking public.

**51A-7.305**      **ATTACHED SIGNS.**

(b) All signs and their words shall be mounted parallel to the building surface to which they are attached, and shall project no more than 18 inches from that surface except as provided in Subsection (e) below.

(c) On the primary facade, the combined effective area of all attached signs may not exceed 25 percent of the total area of the primary facade. On each secondary facade, the combined effective area of all attached signs may not exceed 15 percent of the total area of that secondary facade. As applied to a building with multiple occupants, the facade area of each use with a separate certificate of occupancy shall be treated as a separate facade. On any building facade, there may be a maximum of eight words which contain any character of a height equal to or exceeding four inches and pertain to any premise or any non-residential occupancy. Words consisting of characters less than four inches high may be used without limit.

*This is the only sign proposed on this façade. The sign occupies less than 1% of the 105,372 square-foot façade and less than .5% of the allowance for a secondary facade.*

**51A-7.505 PERMIT PROCEDURES FOR SPECIAL PROVISION SIGN DISTRICTS.**

(B) **Factors the committee shall consider.** In reviewing an application, the committee shall first consider whether the applicant has submitted sufficient information for the committee to make an informed decision. If the committee finds the proposed sign to be consistent with the special character of the special provision sign district, the committee shall make a recommendation of approval to the city plan commission. **The committee shall consider the proposed sign in terms of its appropriateness to the special provision sign district with particular attention to the effect of the proposed sign upon the economic structure of the special provision sign district and the effect of the sign upon adjacent and surrounding premises without regard to any consideration of the message conveyed by the sign.** After consideration of these factors, the committee shall recommend approval or denial of the application and forward that recommendation to the city plan commission.

(6) Decision by the commission. Upon receipt of a recommendation by the committee, the commission shall hold a public hearing to consider the application. At least 10 days before the hearing, notice of the date, time, and place of the hearing, the name of the applicant, and the location of the proposed sign must be published in the official newspaper of the city and the building official shall serve, by hand-delivery or mail, a written notice to the applicant that contains a reference to this section, and the date, time, and location of this hearing. A notice sent by mail is served by depositing it properly addressed and postage paid in the United States mail. In addition, if the application is for a detached sign or for an attached sign that has more than 100 square feet of effective area, the applicant must post the required number of notification signs in accordance with Section 51A-1.106. **In making its decision, the commission shall consider the same factors that were required to be considered by the committee in making its recommendation.** If the commission approves the application, it shall forward a certificate of appropriateness to the building official within 15 days after its approval. If the commission denies the application, it shall so inform the building official in writing. Upon receipt of the written denial, the building official shall so advise the applicant within five working days of the date of receipt of the written notice.

**Property Ownership**

WDC FUB OFFICE OWNER LLC  
1845 Woodall Rodgers Fwy  
Dallas, TX 75201

Officer names: See Attached

**Tenant Ownership**

Gary Reed & McGraw LLP  
1300 Post Oak Blvd. Suite 2000  
Houston, TX 77056

Officer names: See Attached

**Officer List:**

Please format your officer list accordingly, use as many lines as needed:

Building Owner: WDC FUB OFFICE OWNER LLC (Legal Entity or Individual)

Building Owner Address: 1845 Woodall Rodgers Freeway Dallas, Tx 75201

Officer for Building Owner: Dupree Scovell Title: Managing Partner & Chief Investment Officer

Officer for Building Owner: Sean Kennerty Title: Vice President- Asset Management

Officer for Building Owner: Ryan Suchala Title: Chief Banking Officer

Tenant Name: Gray Reed & McGraw LLP (Full legal entity)

Corporate Address for Tenant: 1300 Post Oak Blvd. Suite 2000 Houston, TX

Officer for Tenant: Kyle Sanders Title: Managing Partner

Officer for Tenant: Cary Gray Title: Chairman

Officer for Tenant: Darrell Armer Title: Dallas Managing Partner

**SSDAC Action:**

**April 14, 2026**

**MOTION:** It was moved to approve:

An application for a Certificate of Appropriateness by Gary Houser of 4D Signworx LTD., for a 72.3-square-foot back lit channel letters sign mounted on a four-inch deep pan on the Eastern facing façade at 1845 WOODALL RODGERS FWY (EAST ELEVATION).

Maker: Hardin  
Second: Webster  
Result: Carried: 3 to 0

For: 3 - Peadon, Hardin and Webster  
Against: 0 - none  
Absent: 2 - Dumas and Coffman  
Conflict: 0 - none

Speakers: none

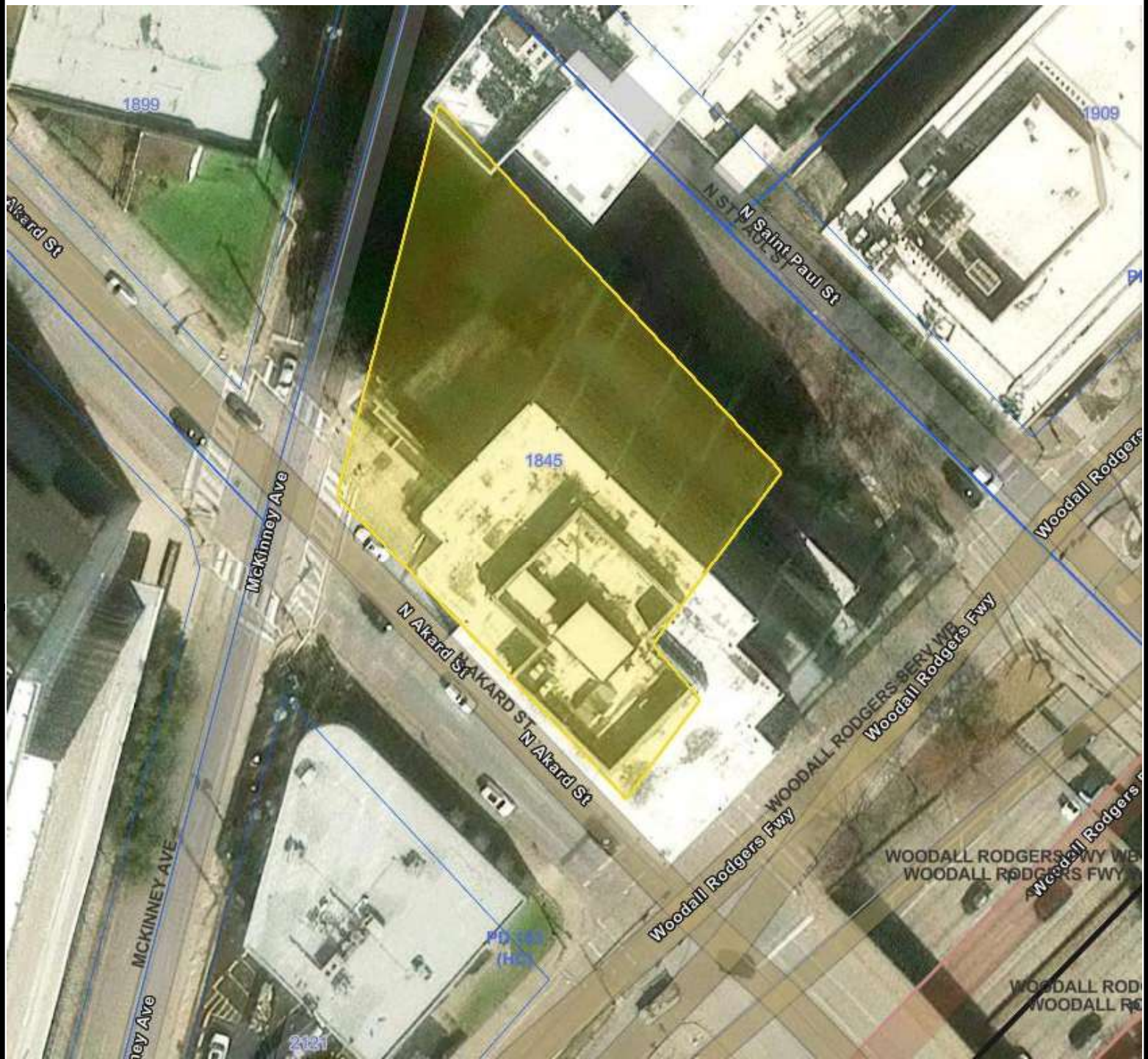

Printed Date: 4/13/2026



Aerial Map - 1845 Woodall Rodgers Fwy

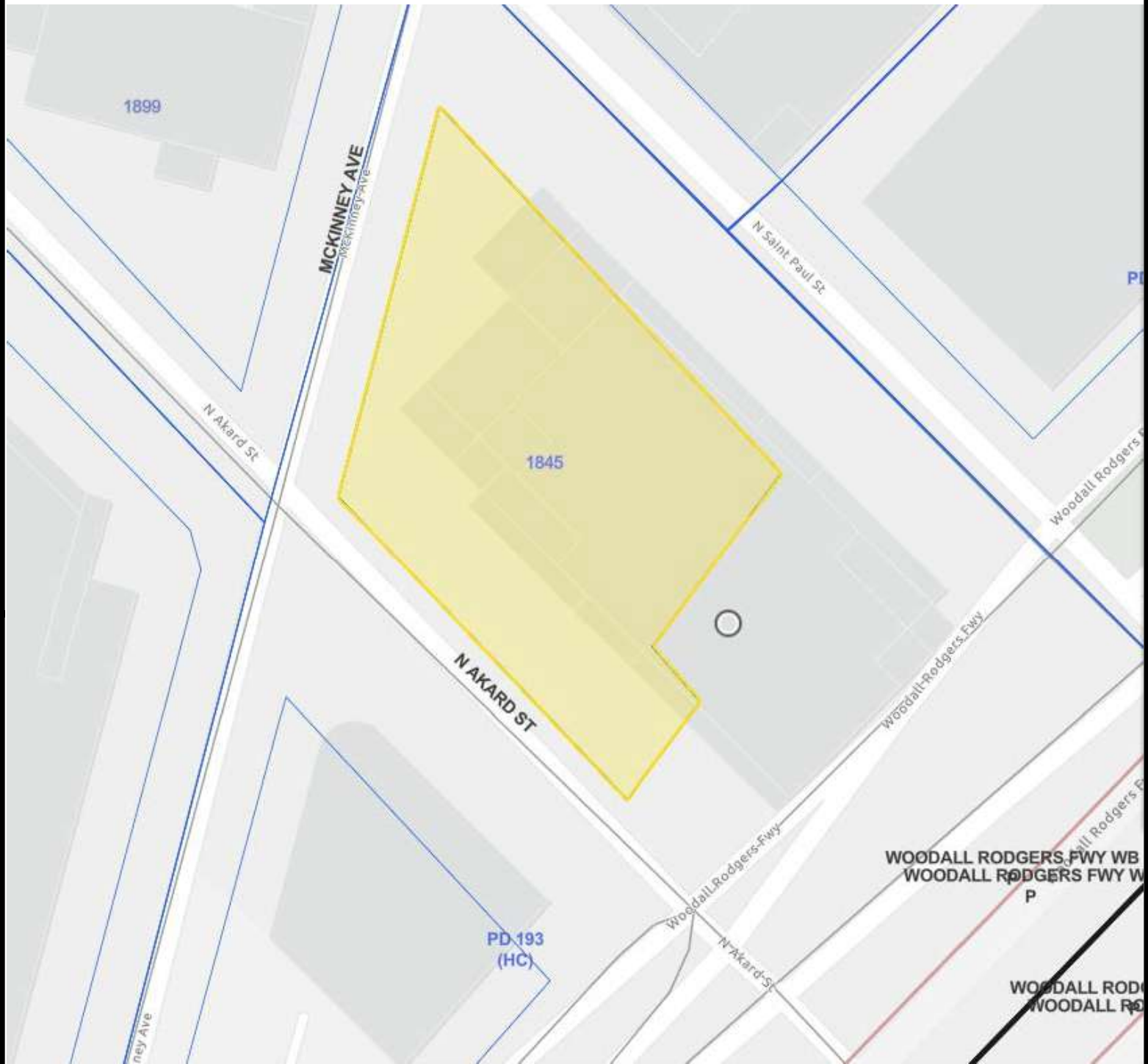

Printed Date: 4/13/2026



# Zoning Map - 1845 Woodall Rodgers Fwy



214539 – GRAY REED & MCGRAW, LLP –

1845 WOODALL RODGERS FWY | STE (TBD), DALLAS, TX 75201

MANUFACTURE AND INSTALL (2) SETS OF INTERNALLY ILLUMINATED CHANNEL LETTERS & CHANNEL MODULES MOUNTED TO ALUMINUM FRAME MOUNTED TO BUILDING [PER ENGINEERS SPECIFICATIONS

SIGN TYPE
M&I (1) SET CHANNEL LETTERS MOUNTED TO ALUMINUM PAN BACKER.
MATERIAL SPEC
AL1: 1/8" ALUMINUM
PAINT SPEC - SATIN FINISH
P1: MP WHITE SP
VINYL SPEC
V1: CARDINAL RED 3M 3630-53



NIGHT VIEW

SIGN A

INSTALL ON BUILDING FACADE BETWEEN LEVELS 13 AND 14.

Approx. 140' from grade



140'-0"

EAST ELEVATION  
SCALE: N.T.S.

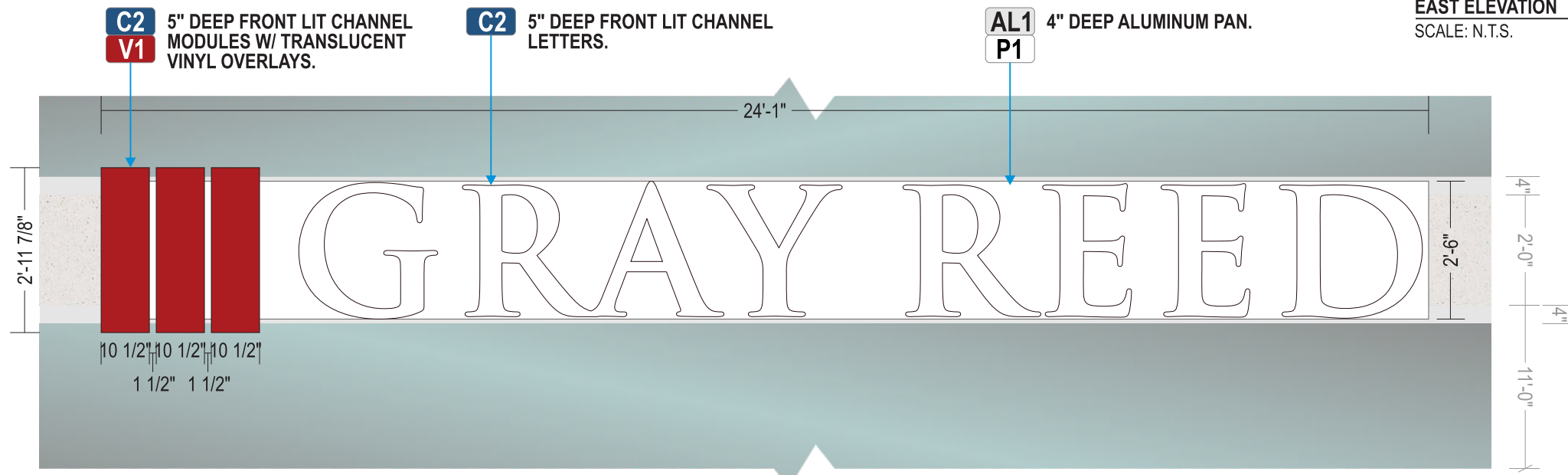
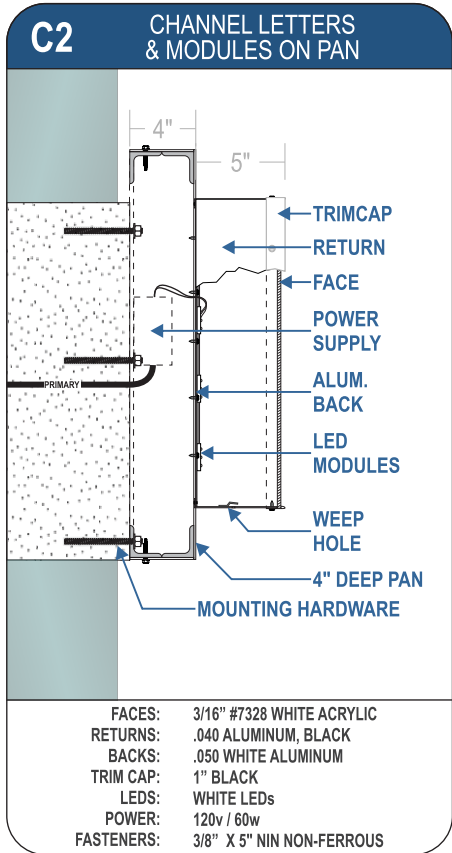

70.24 SQ FT

SIGN LAYOUT  
SCALE: 3/8"=1'-0"

THIS IS ONLY AN ARTIST RENDERING. FINISHED PROJECT MAY VARY SLIGHTLY IN SIZE AND COLOR.

PERMITTING



PROJECT INFO
CLIENT: N HOUSE GRAY REED
ADDRESS: 18455 WOODALL RODGERS FRWY
CITY, STATE: DALLAS, TEXAS 75102
DATE: 09.12.25
SALES REP: JG
DRAWN BY: KR

DRAWING NUMBER
P214539-1
W.O. (E2) NUMBER

#	DATE	REVISIONS	SIGNATURES
1	03.13.26	REV	KR
2	03.16.26	REV	KR
3			
4			
5			
6			

30-11

ESTIMATION
CLIENT APPROVAL SIGNED: DATE:
LANDLORD APPROVAL SIGNED: DATE:
SALES SIGNED: DATE:

ESTIMATION
APPROVAL _____
APPROVAL _____ FOR ACTUAL COLORS OF ITEMS DEPICTED IN THIS DESIGN REFER TO SAMPLES, AS MONITORS & PRINTERS VARY.
APPROVAL _____ CLIENT IS RESPONSIBLE FOR SUPPLING VECTOR AND/OR HIGH-RES TYPICAL BRANDING FILES PRIOR TO PRODUCTION TO AVOID A SET-UP FEE.
APPROVAL _____

SPECIFICATION
THIS SIGN IS INTENDED TO BE INSTALLED IN ACCORDANCE WITH THE REQUIREMENTS OF ARTICLE 600 OF THE NATIONAL ELECTRICAL CODE AND/OR OTHER APPLICABLE LOCAL CODES. THIS INCLUDES PROPER GROUNDING AND BONDING OF THE SIGN.
ILLUMINATED
120 or 277 VOLT ELECTRICAL SERVICE
ELECTRICAL LOAD: 2 AMPS @ 120V 20 AMP CIRCUIT(S): 1 @ 120V
CLIENT TO PROVIDE ALL PRIMARY ELECTRICAL SERVICES TO THE SIGN UNLESS OTHERWISE SPECIFIED
PAGE 1 OF 4

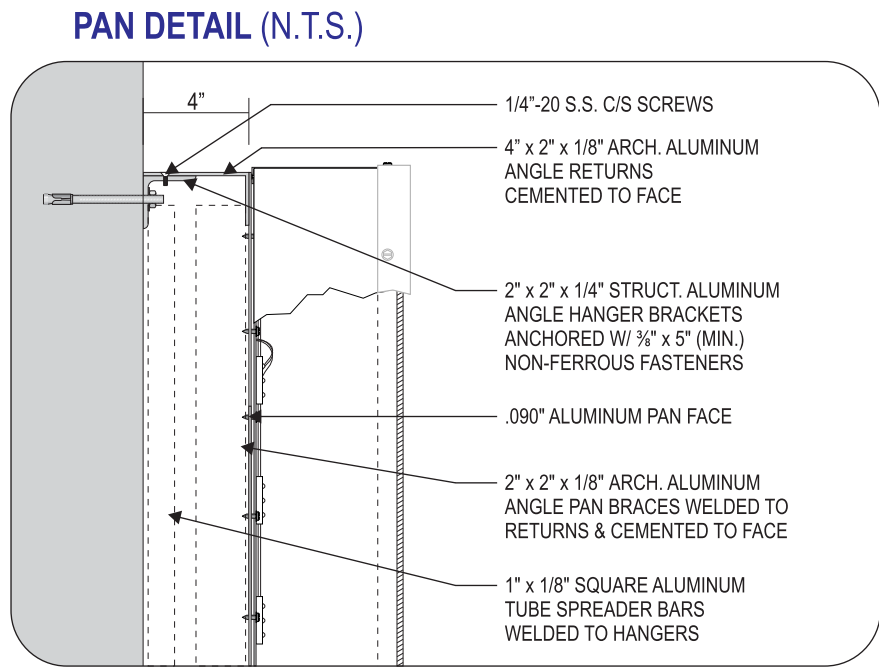
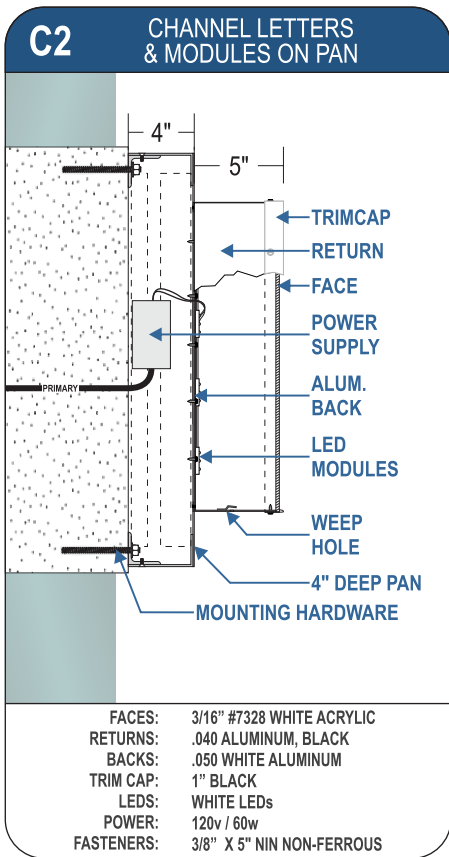

ALL ALUMINUM WELDS TO BE PERFORMED USING MIG METHOD WITH 4043 ALLOY ALUMINUM SPOOL WIRE @ .035" DIAMETER AND ARGON SHIELDING GAS.

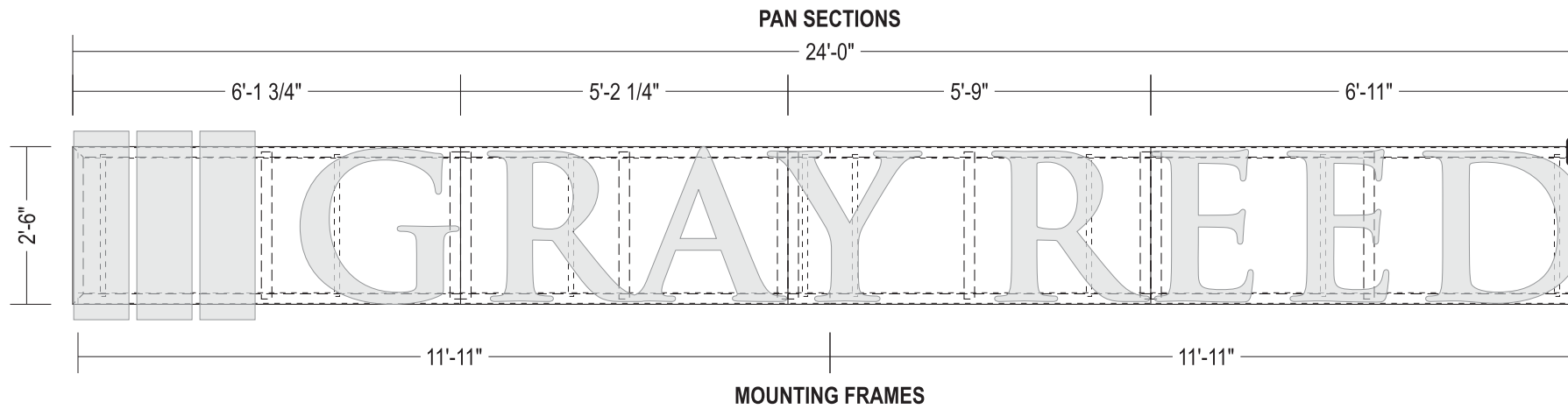
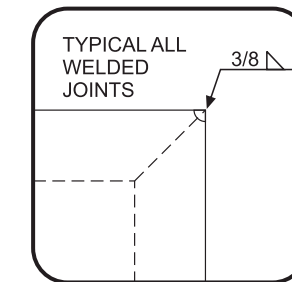

MOUNT FRAMES TO BUILDING FACADE USING 1/2" x 5" (MIN.) NON-FERROUS HARDWARE. SEAL ALL PENETRATIONS.

**SIGN LAYOUT**  
SCALE: 3/8"=1'-0"

THIS IS ONLY AN ARTIST RENDERING. FINISHED PROJECT MAY VARY SLIGHTLY IN SIZE AND COLOR.

**PERMITTING**



**PROJECT INFO**

CLIENT: N HOUSE GRAY REED  
 ADDRESS: 18455 WOODALL RODGERS FRWY  
 CITY, STATE: DALLAS, TEXAS 75102  
 DATE: 09.12.25  
 SALES REP: JG  
 DRAWN BY: KR

**DRAWING NUMBER**

**P214539-1**

**W.O. (E2) NUMBER**

#	DATE	REVISIONS	SIGNATURES
1	03.13.26	REV	KR
2	03.16.26	REV	KR
3			
4			
5			
6			

30-12

ESTIMATION	SPECIFICATION
APPROVAL _____ APPROVAL _____ APPROVAL _____ APPROVAL _____	THIS SIGN IS INTENDED TO BE INSTALLED IN ACCORDANCE WITH THE REQUIREMENTS OF ARTICLE 600 OF THE NATIONAL ELECTRICAL CODE AND/OR OTHER APPLICABLE LOCAL CODES. THIS INCLUDES PROPER GROUNDING AND BONDING OF THE SIGN. CLIENT IS RESPONSIBLE FOR SUPPLYING VECTOR AND/OR HIGH-RES TYPICAL BRANDING FILES PRIOR TO PRODUCTION TO AVOID A SET-UP FEE.

**ILLUMINATED**

120 or 277 VOLT ELECTRICAL SERVICE

ELECTRICAL LOAD: 2 AMPS @ 120V  
20 AMP CIRCUIT(S): 1 @ 120V

CLIENT TO PROVIDE ALL PRIMARY ELECTRICAL SERVICES TO THE SIGN UNLESS OTHERWISE SPECIFIED

PAGE 2 OF 4

SIGN TYPE
M&I (1) SET CHANNEL LETTERS MOUNTED TO ALUMINUM PAN BACKER.
MATERIAL SPEC
AL1: 1/8" ALUMINUM
PAINT SPEC - SATIN FINISH
P1: MP WHITE SP
VINYL SPEC
V1: CARDINAL RED 3M 3630-53



NIGHT VIEW

INSTALL ON BUILDING FACADE BETWEEN LEVELS 13 AND 14.

Approx. 140' from grade



EAST ELEVATION  
SCALE: N.T.S.

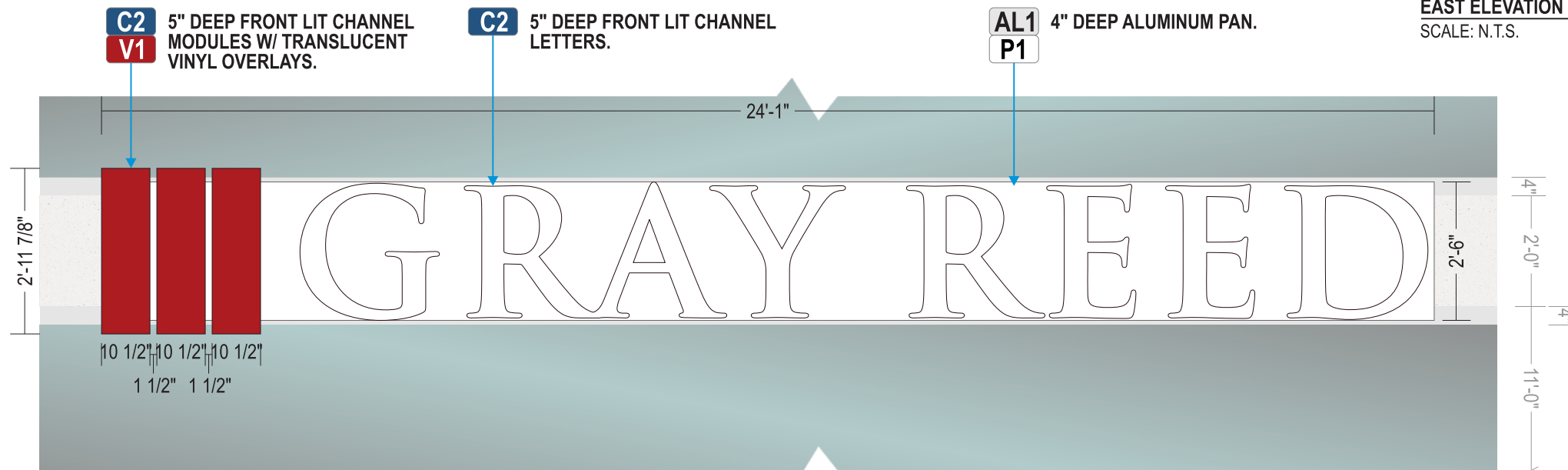
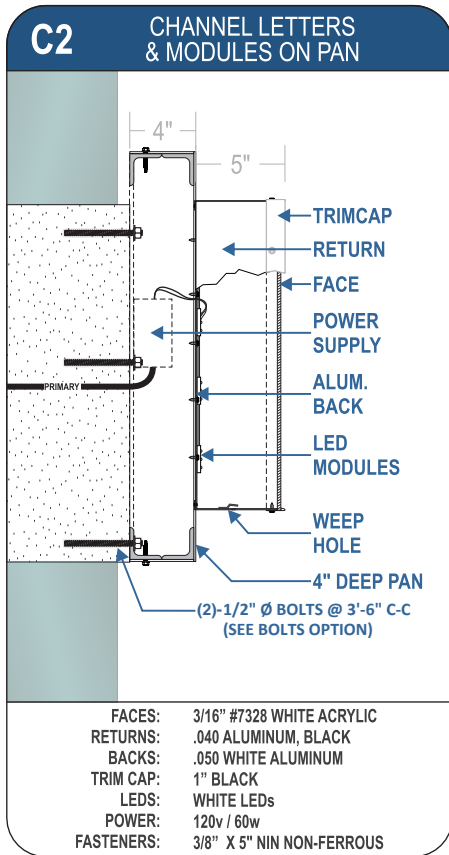

**SIGN LAYOUT**  
SCALE: 3/8"=1'-0"

THIS IS ONLY AN ARTIST RENDERING. FINISHED PROJECT MAY VARY SLIGHTLY IN SIZE AND COLOR.

**WORK ORDER**



PROJECT INFO	
CLIENT:	N HOUSE GRAY REED
ADDRESS:	18455 WOODALL RODGERS FRWY
CITY, STATE:	DALLAS, TEXAS 75102
DATE:	09.12.25
SALES REP:	JG
DRAWN BY:	KR

DRAWING NUMBER
214539-1
W.O. (E2) NUMBER
214539-02

#	DATE	REVISIONS	SIGNATURES
1	9/17/25	REVISIONS	KR
2	12/12/25	SURVEY UPDATES	SF
5	1/7/26	SIZE UPDATE	SF
12	2/19/26	DIFFERENT OPTIONS TOGETHER	KM
W1	3/5/26	UPDATE STROKE THICKNESS ON LETTERS	KM
		30-13	

SIGNATURES	
CLIENT APPROVAL	SIGNED: DATE:
LANDLORD APPROVAL	SIGNED: DATE:
SALES	SIGNED: DATE:

ESTIMATION	
APPROVAL	_____
APPROVAL	_____
APPROVAL	_____
APPROVAL	_____

**SPECIFICATION**

THIS SIGN IS INTENDED TO BE INSTALLED IN ACCORDANCE WITH THE REQUIREMENTS OF ARTICLE 600 OF THE NATIONAL ELECTRICAL CODE AND/OR OTHER APPLICABLE LOCAL CODES. THIS INCLUDES PROPER GROUNDING AND BONDING OF THE SIGN.

ILLUMINATED	
120 or 277 VOLT ELECTRICAL SERVICE	
ELECTRICAL LOAD: _____	
20 AMP CIRCUIT(S): _____	
CLIENT TO PROVIDE ALL PRIMARY ELECTRICAL SERVICES TO THE SIGN UNLESS OTHERWISE SPECIFIED	

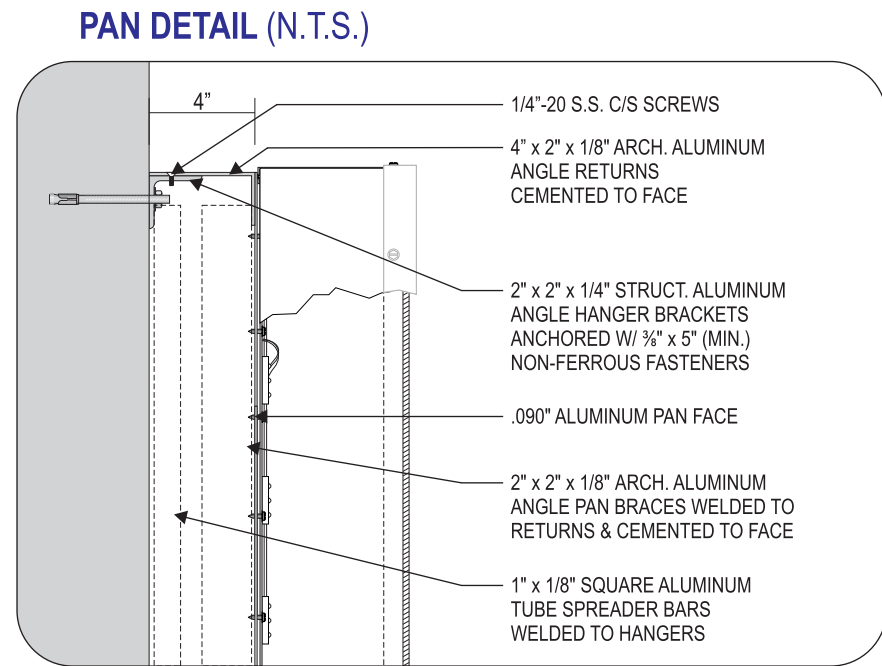
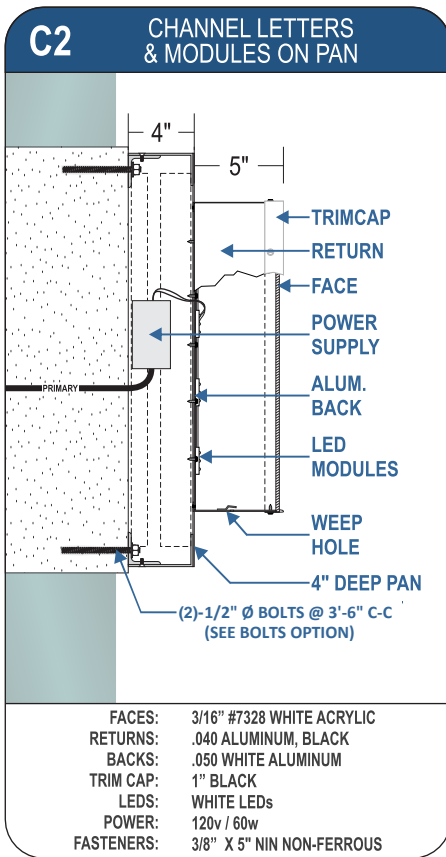

- BOLT OPTIONS:**
1. AT CONCRETE USE HILTI KWIK BOLTS OR APPROVED EQUAL, 1/2" DIA x 3 1/2" EMBED INTO THE CONCRETE. CONCRETE STRUCTURE DESIGNED BY OTHERS.
  2. AT WOOD STUD : USE 1/2" DIA LAG SCREWS x 4" LONG INTO THE WOOD, WOOD STRUCTURE DESIGNED BY OTHERS.
  3. AT EXISTING STEEL STRUCTURE, USE 1/2" DIA NUTS WITH BOLTS.
  4. AT BRICK, USE 1/2" DIA HILTI HIT HY 270 ADHESIVE W 3 1/8" EMBED INTO THE BRICK.

ALL ALUMINUM WELDS TO BE PERFORMED USING MIG METHOD WITH 4043 ALLOY ALUMINUM SPOOL WIRE @ .035" DIAMETER AND ARGON SHIELDING GAS.

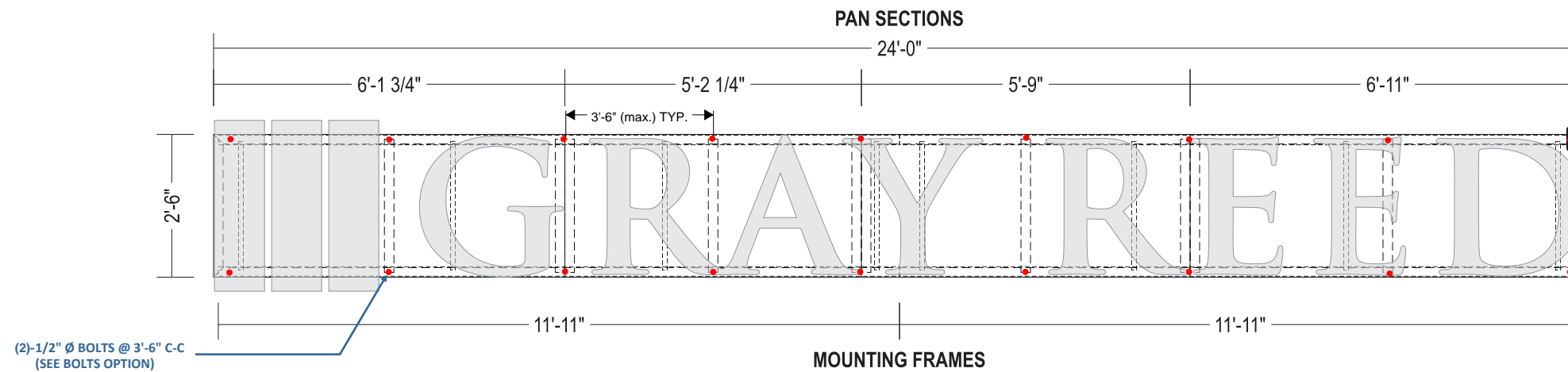
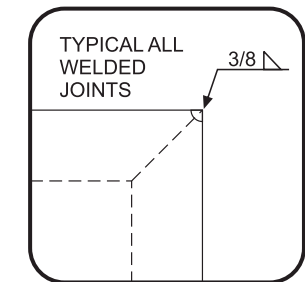

MOUNT FRAMES TO BUILDING FACADE USING 1/2" x 5" (MIN.) NON-FERROUS HARDWARE. SEAL ALL PENETRATIONS.



**SIGN LAYOUT**  
 SCALE: 3/8"=1'-0"

THIS IS ONLY AN ARTIST RENDERING. FINISHED PROJECT MAY VARY SLIGHTLY IN SIZE AND COLOR.

**WORK ORDER**



**PROJECT INFO**

CLIENT: N HOUSE GRAY REED  
 ADDRESS: 18455 WOODALL RODGERS FRWY  
 CITY, STATE: DALLAS, TEXAS 75102  
 DATE: 09.12.25  
 SALES REP: JG  
 DRAWN BY: KR

**DRAWING NUMBER**  
 214539-1

**W.O. (E2) NUMBER**  
 214539-02

#	DATE	REVISIONS	SIGNATURES
1	9/17/25	REVISIONS	KR
2	12/12/25	SURVEY UPDATES	SF
5	1/7/26	SIZE UPDATE	SF
12	2/19/26	DIFFERENT OPTIONS TOGETHER	KM
W1	3/5/26	UPDATE STROKE THICKNESS ON LETTERS	KM

30-14

SIGNATURES	ESTIMATION	SPECIFICATION
CLIENT APPROVAL SIGNED: DATE:	APPROVAL _____	THIS SIGN IS INTENDED TO BE INSTALLED IN ACCORDANCE WITH THE REQUIREMENTS OF ARTICLE 600 OF THE NATIONAL ELECTRICAL CODE AND/OR OTHER APPLICABLE LOCAL CODES. THIS INCLUDES PROPER GROUNDING AND BONDING OF THE SIGN.
LANDLORD APPROVAL SIGNED: DATE:	APPROVAL _____	
SALES SIGNED: DATE:	APPROVAL _____	
	APPROVAL _____	

**ILLUMINATED**

120 or 277 VOLT ELECTRICAL SERVICE

ELECTRICAL LOAD:  
 20 AMP CIRCUIT(S):

CLIENT TO PROVIDE ALL PRIMARY ELECTRICAL SERVICES TO THE SIGN UNLESS OTHERWISE SPECIFIED

PAGE 2 OF 4

**CLIENT: N HOUSE GRAY REED**  
**ADDRESS: 18455 WOODALL RODGERS FRWY**  
**CITY, STATE: DALLAS, TEXAS 75102**

Date: 3/17/2026 IBC2021

**Wind Load Calcs**

Vult ( 3 sec gust) per ASCE 7-16 105 mph kd= 0.85  
 Exposure: B  
 k<sub>z</sub>\_mwfrs= 1.09 kzt= 1  
 G= 0.85 Risk Cat II  
 qh 0.00256\*k<sub>z</sub>\*k<sub>z</sub>\*kd\*V<sup>2</sup>  
 qh\_mwfrs= 26.15 psf

**Wind load- Horizontal**

b= 288.75 in Clearance Ratio( s/H): 0.01  
 h= 2,580.00 in Aspect Ratio(B/s): 8.02  
 s= 36.00 in  
 Cf= 1.85  
 MWFRS: p= q\_mwf\*G\*Cf\*0.6 0.6 factor for asd p= 24.67 psf  
 wind shear  
 Projected area , gross 72.19 ft<sup>2</sup> 1.78 k  
 Area receiving wind 100%  
 Net Projected area 72.19 ft<sup>2</sup> 1.78 k

**Wall Connection**

Sign Wt-10 psf max 10 721.88 lbs  
 Check 3/8" thru bolt  
 Tension force on each bolt due to wind 0.13 k  
 Shear force on each bolt due to self weight 0.053 k  
 Design Tensile stress, ft 0.66 ksi  
 Allowable tensile stress 22.50 ksi  
 Design Shear stress, fv 0.27 ksi  
 Allowable shear on bolt 13.50 ksi  
 Since shear stress is low, combined shear and tension is ok  
 Hence, provide (2) - 1/2" bolts @ 3'-6" C-C to fasten the Alum. Frame with wall.

Bolt size	1/2 in
Bolt area	0.20 in <sup>2</sup>
F <sub>nt</sub> =	45 ksi
F <sub>nv</sub> =	27 ksi
	OK
	OK

**Also, calculate Hilti Kwik Bolts At concrete**

1/2" dia Hilti KB3  
 Allowable Tension 2185 # OK  
 Allowable shear 2415 # OK  
 Hence, Provide (2)-1/2" Hilti Kwik bolts x 3 1/2" eff. embedment @ 3'-6" C-C to fasten the Alum. Frame with concrete wall.

**Also, calculate 3/8" dia lag screws, assuming southern pine connecting 2x or wood**

1/2" dia x 4" long  
 Withdrawl capacity 1284 # OK  
 Lateral Capacity 464 # OK  
 Hence, Provide (2)-1/2" Lag Screw x 4" long. @ 3'-6" C-C to fasten the Alum. Frame with wood blocking.

**Also, calculate Hilti HY 270 at bricks**

1/2" dia Hilti Hit Hy 270  
 Allowable Tension w sp and edge reduction 452.50 lbs OK  
 Allowable Shear sp and edge reduction 303.30 lbs OK  
 Hence, Provide (2)-1/2" Hilti HY 270 x 3 1/8" eff. embedment @ 3'-6" C-C to fasten the Alum. Frame with Brick wall.



03/17/2026  
 SHANGRILA ENGINEERS  
 TBPE # 17244